

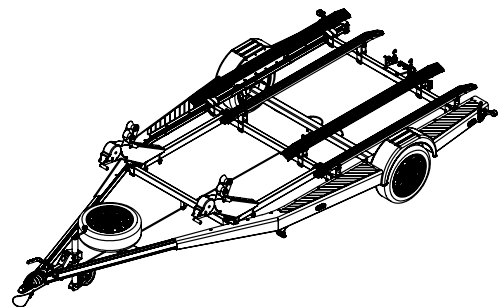

2498 mm 3420 mm

DMC 1300 kg 306 kg 994 kg

2498 mm 5776 mm 1097 mm

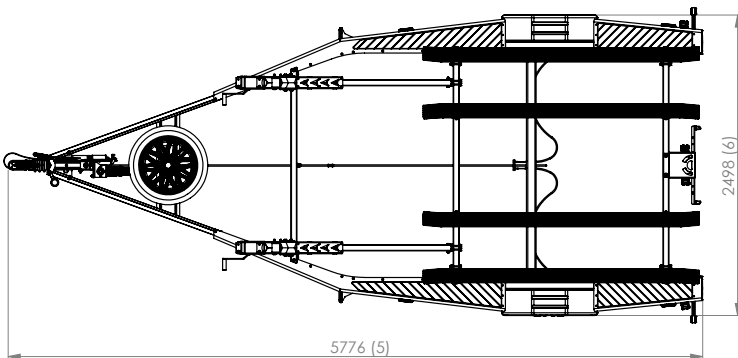
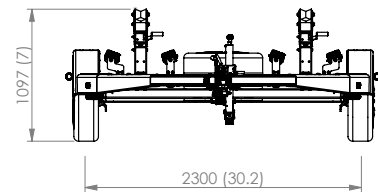
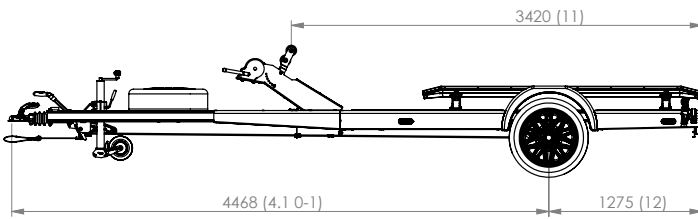

## ZNACZENIE IKON / THE MEANING OF THE ICONS BEDEUTUNG VON SYMBOLEN / LA SIGNIFICATION DES ICÔNES



Dopuszczalna masa całkowita [kg]  
Gross vehicle weight [kg]  
Zulässiges Gesamtgewicht [kg]  
Poids total autorisé en charge [kg]



Ładowność [kg]  
Load capacity [kg]  
Nutzlast [kg]  
Charge utile [kg]



Masa własna [kg]  
Complete kerb weight [kg]  
Leergewicht [kg]  
Poids à vide [kg]



Rodzaj osi: Hamowana  
Axles type: Braked  
Typ der Achse: Gebremst  
Type d'essieux: Freiné



Rodzaj kół  
Wheels type  
Typ der Räder  
Type de roues



Liczba osi [sztuk]  
Number of axles  
Anzahl der Achsen  
Nombre d'essieux



Szerokość [mm]  
Width [mm]  
Breite [mm]  
Largeur [mm]



Długość [mm]  
Length [mm]  
Länge [mm]  
Longueur [mm]



Wysokość [mm]  
Height [mm]  
Höhe [mm]  
Hauteur [mm]



Maksymalna długość powierzchni ładunku [mm]  
Maximum length of the loading surface [mm]  
Maximale Länge der Ladefläche [mm]  
Longueur maximale de la surface de chargement [mm]



Maksymalna szerokość powierzchni ładunku [mm]  
Maximum width of the loading surface [mm]  
Maximale Breite der Ladefläche [mm]  
Largeur maximale de la surface de chargement [mm]



## WYPOSAŻENIE STANDARDOWE / STANDARD EQUIPMENT STANDARD AUSRÜSTUNG / ÉQUIPEMENT STANDARD



Koło podporowe  
Support wheel  
Stützrad  
Roue jockey



Regulowany słupek wciągarki  
Adjustable winch post  
Einstellbarer Windenpfosten  
Poteau de treuil réglable



Ręczna wciągarka pasowa  
Manual winch  
Handwinde  
Treuil manuel



Rolka dziobowa  
Bow roller  
Bugrolle  
Diabolo central



Łożyska wodoodporne  
Waterproof bearings  
Wasserdichte Lager  
Roulements étanches



Pasy ze zwijaczem  
Retractor belts  
Gurte mit Aufroller  
Ceintures avec enrouleur



Schodek boczny  
Side step  
Seitenstufe  
Marchepied latéral



Malowanie proszkowe  
Powder painting  
Pulvermalerei  
Peinture en poudre



System otwierania lamp tylnych  
Rear lamp opening system  
Rücklichtöffnungssystem  
Système d'ouverture du feu arrière



Tylne lampy LED  
LED rear lamps  
LED-Heckleuchten  
Feux arrière LED



## WYPOSAŻENIE DODATKOWE / ADDITIONAL EQUIPMENT OPTIONALES ZUBEHÖR / ÉQUIPEMENT SUPPLÉMENTAIRE



Zabezpieczenie antykradzieżowe  
Anti-theft protection  
Diebstahlschutz  
Protection antivol



Koło zapasowe  
Spare wheel  
Ersatzrad  
Roue de secours



Amortyzatory do osi z mocowaniem  
Axle shock absorbers with mountings  
Achsstoßdämpfer mit Befestigung  
Amortisseurs d'essieux avec fixation



Płozy-rolki  
Skids and rollers  
Kufen und Rollen  
Patins et rouleaux